

RF Coaxial Adapter, 1.00 mm (M) to 1.85 mm (F)

P/N: MLA-100MST-185FST

Package Contents

Connector	1 Pc
Protection Cap	2 Pcs

Adapter Configuration

End 1	1.00 mm Male
End 2	1.85 mm Female

Materials

Description	Material	Finish
Center Pin	Beryllium Copper	Gold-Plated
Shell	Stainless Steel	Passivated

Electrical Specifications

Impedance	50 Ohms
Frequency Range	DC to 67 GHz
V.S.W.R.	1.20 max. at 67 GHz
Insertion Loss	≤0.49 dB max. at 67 GHz

Mechanical Specifications

Durability	1.00 mm Male ≥ 500 Cycles
	1.85 mm Female ≥ 1000 Cycles

Environmental Specifications

Operating Temperature Range	-55 to +85 °C
-----------------------------	---------------



Features:

- Designed for Repeatability and Accuracy
- Wide Variety of Mating Interfaces
- Customizable

Applications:

- High Speed IO Test Setup: Instrumentation Connection to DUT Eval Boards
- Precision Connector Savers
- Adapts Two Different Precision Interfaces



CAD Drawing

MLA-100MST-185FST

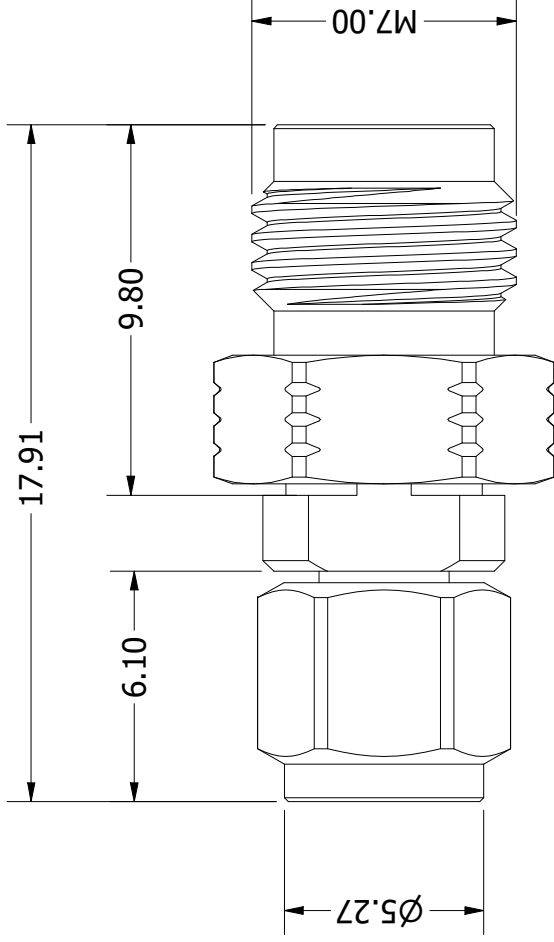

Title:

RF Coaxial Adapter, 1.00 mm (M) to
1.85 mm (F)

Notes:

1. All dimensions are in millimetres unless otherwise specified.
2. These characteristics are typical and for reference.

multiLane

www.multilaneinc.com

sales@multilaneinc.com

Rev: A

Scale: 5:1