

Innovation for the next generation

ML4015E

Optical and Electrical Sampling Oscilloscope



Ideal for < 53.125 GBaud PAM4 and NRZ transceiver testing | Supports 802.3 measurements, SSPRQ patterns | Open Eye MSA support | <100G per wavelength and channel characterization

Summary

The Data Center Interconnect market is rapidly transitioning to 50G Ethernet and 32GT/64GT PCIe, as well as 100G per channel for both optical and electrical interfaces. Cost-effective characterization tools are required to enable this technology transition and to accelerate the deployment of Data Center Interconnects, such as optical transceivers and passive cable interconnect.

The characterization of these transceivers introduces a myriad of test and measurement challenges. Besides the 53.125 GBaud PAM4 optical transmitter market, well served by many - typically quite expensive- instruments, there is a strong need for slightly slower standards' measurements. MultiLane introduces the ML4015E Optical and Electrical Sampling Oscilloscopes as a well-correlated alternative to incumbent solutions at an excellent-value price point.

ML4015E

Optical and Electrical DSO

Introduction

The ML4015E is a fully featured, cost effective single channel sampling oscilloscope. It can be configured to have an optical roll-off of either 25, 33 or 42 GHz. The supported wavelengths range from 1260 to 1650 nm single mode or 700 to 870 nm multimode. The ML4015E can also be configured with a 33 GHz differential electrical sampler.

Key Features

The ML4015E family of optical DSOs boasts an extensive set of features and functions that are unique in the industry. These include:

- A noise floor of 5 μ W resp. 6-7 μ W (25 vs 42 GHz roll-off)
- Sensitivity level of -11 dBm for a 25.78125 Gbps NRZ signal
- Up to 50 - 70 MHz sampling rate
- Less than 10 seconds TDECQ on an SSPRQ pattern
- FPGA-based architecture enabling TDECQ measurements via capture of SSPRQ and PRBS16 patterns
- An extensive library of built-in DSP filters such as Bessel-Thomson, CTLE, DFE, FFE, de-embedding, and component emulation, all available free of charge in the standard GUI
- Comprehensive eye mask library
- Individual impulse response calibration performed at factory
- Compact instrument footprint with a ruggedized enclosure and handle
- Comprehensive set of APIs and associated sample scripts to accelerate automation development under Linux and Windows, supporting Python, LabView, MATLAB, and C#

Typical Optical Applications

- Production/manufacturing testing of electrical and optical transceivers
- Benchtop characterization of optical circuits
- Qualification of PAM-N and NRZ optical modulators and drivers
- Sensitivity testing of optical receivers
- System testing with a clock recovery

Typical Electrical Applications

- TP1a stress calibration
- SERDES characterization
- Receiver electrical output characterization
- Benchtop characterization of electrical circuits

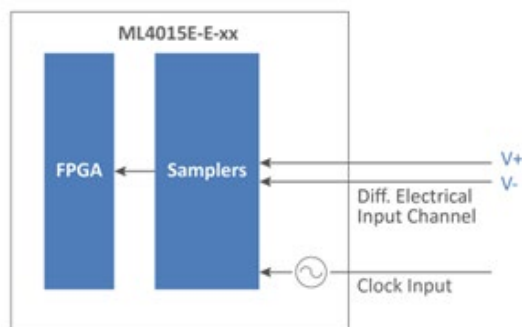

Figure 1: Schematics of the ML4015E-35

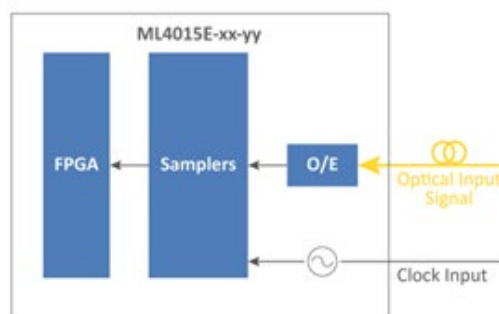

Figure 2: Schematics of the ML4015E-OPT

Optical Specifications

Parameters	Specifications
SM Wavelength	1260 - 1650 nm
MM Wavelength	700 - 870 nm
Calibrated Wavelengths	1310 and 850 nm
Optical Bandwidth	42 GHz Single Mode 33 GHz or 25 GHz Broadband
Noise RMS at 1310 nm	5 μ W at 25 GHz 6 - 7 μ W at 42 GHz and 33 GHz
Sensitivity at 1310 nm at 25.78 G NRZ	< -10 dBm
Sensitivity at 850 nm at 25.78 G NRZ	< -9 dBm
Intrinsic Jitter	400 fs rms
Input Power Damage Level	10 dBm
Fiber Input SM	9 / 125 μ m
Fiber Input MM	50 / 125 μ m
Connector	FC-UPC
Analog Sampling Hardware Resolution	14 bits
Clock Input Bandwidth	0.1 - 20 GHz
Clock Input Swing	225-1800 mVpp
Clock Input Connector	Key 2.92 mm (f), 50 Ω
Pattern Capture	> 8 M Samples
Sampling Frequency	50 - 70 MHz
Memory	8 MSa
Pattern Lock	Up to PRBS16, SSPRQ
Temperature Range	0 - 75 $^{\circ}$ C
Room Temperature Range	0 - 30 $^{\circ}$ C
Line Power	100 - 240 V AC, 50 / 60 Hz

Electrical Specifications

Parameters	Specifications
Electrical Amplitude	< 600 mV SE and < 1200 mV Diff
Electrical Bandwidth	33 GHz
Intrinsic Jitter	350 fs rms
Electrical Channel Connectors	Key 2.4mm Female. (default) 2.92 mm on request
Analog Sampling Hardware Resolution	14 bits
Clock Input Bandwidth	0.1 - 20 GHz
Clock Input Swing	225 - 1800 mVpp
Clock Input Connector	Key 2.92 mm (f), 50 Ω
Pattern Capture	> 8 M Samples
Sampling Frequency	50 - 70 MHz
Memory	8 MSa
Pattern Lock	Up to PRBS16, SSPRQ
Temperature Range	0 - 75 $^{\circ}$ C
Room Temperature Range	0 - 30 $^{\circ}$ C
Line Power	100 - 240 V AC, 50 / 60 Hz

Recommended PC Specifications

OS	Windows 11 64-bit
Processor	Core i7 / Ryzen 7
Memory	32 GB
GPU	4 GB (Dedicated)
Storage	10 GB (Dedicated)

Minimum PC Specifications

OS	Windows 10 64-bit
Processor	Core i5 / Ryzen 5
Memory	16 GB
GPU	2 GB (Dedicated)
Storage	5 GB (Dedicated)

Supported DSP Functions

- Frequency response correction of O/E & analog front end
- Nth-Order Bessel-Thomson
- CTLE adaptive or manual
- FFE adaptive or manual
- DFE adaptive or manual
- De-embedding or embedding of four-ports (.s4p) and two-ports (.s2p) files
- Moving average



Figure 3: Multi-Signal Display Feature

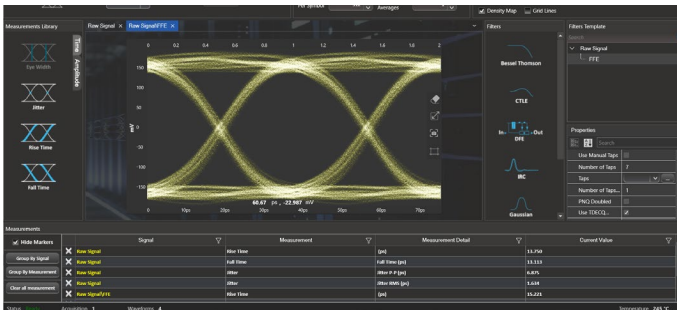

Figure 4: 26.5625 GBaud Optical Eye Diagram

Measurements	Unit	Current	D
OMA(outer)	µW	340.62	X
OMA(outer)_Level3	µW	463.21	X
OMA(outer)_Level0	µW	122.59	X
OMA(outer)	dBm	-4.68	X
Open Eye MSA DC Balance		0.0707	X
Open Eye MSA Inter Eye Skew	UI	0.00	X
Open Eye MSA Symbol Symmetry		0.96	X
Open Eye MSA E1-Flow	% OMA Outer	12.43	X
Open Eye MSA E1-Hmid	% OMA Outer	11.46	X
Open Eye MSA E1-Hupp	% OMA Outer	10.36	X
Open Eye MSA E1-Wlow	UI	0.26	X
Open Eye MSA E1-Wmid	UI	0.26	X
Open Eye MSA E1-Wupp	UI	0.23	X
Open Eye MSA VEC Deterministic	dB	0.3107	X
Open Eye MSA VEC Statistical	dB	1.09	X
Open Eye MSA Mask Failing Points		453.00	X
Extinction Ratio (outer)	dB	5.89	X
RLM(IEEE 802.3 clause 94)		0.96	X
RLM(IEEE 802.3 Annex 1200)		0.93	X

Figure 5: Supported Open Eye MSA Measurements

Supported Measurements

Coding	Measurements
PAM4	TDECQ
	SNDR
	Open Eye MSA
	RLM
	OMA _{outer}
	Eye Height by BER
NRZ	Eye Width by BER
	Top & Base
	Min & Max
	One & Zero
	Transition Time
	Crossing %
	AOP
	OMA
	Mask
	Peak to Peak
	Eye Amplitude
	Eye Height
	Eye Width
	Jitter
	SNR
ER	
VEC	
Vrms	
RJ	
Noise	

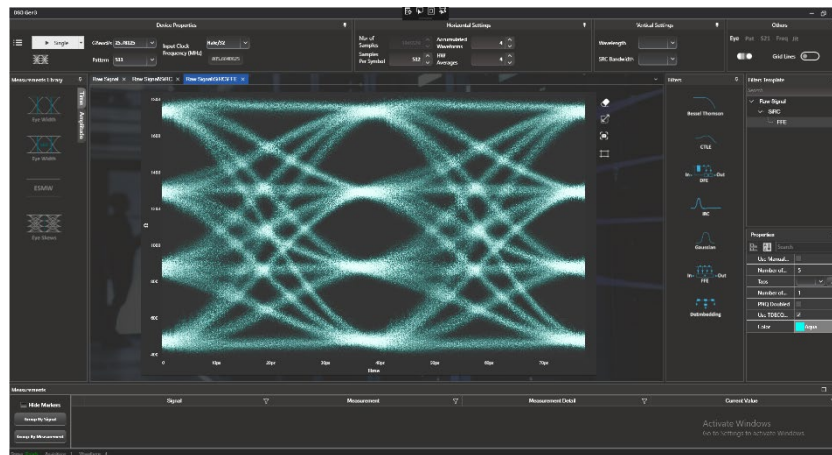

Figure 6: 25.78125 GBaud Optical Eye Diagram – SRC+FFE

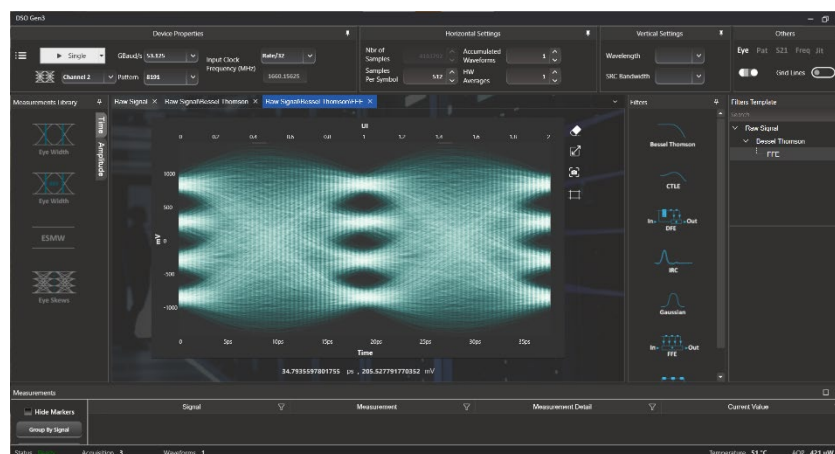

Figure 7: 53.125 GBaud Electrical Eye Diagram – Bessel Thomson + FFE

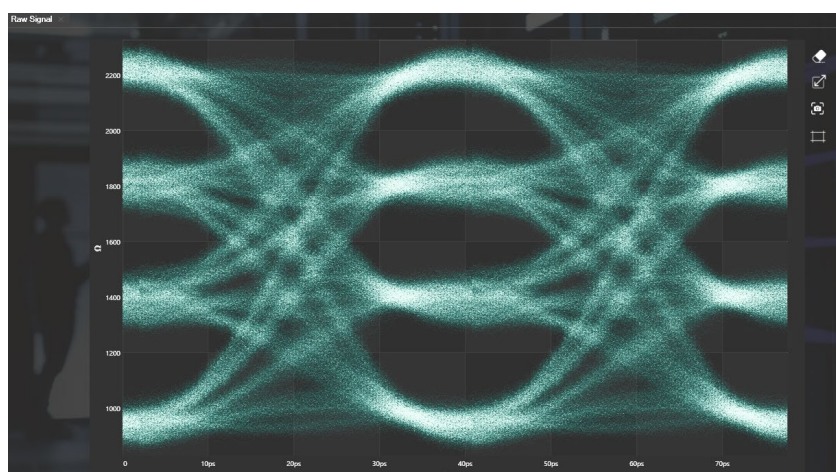

Figure 8: 26.5625 GBaud Optical Eye Diagram – Raw Diagram

Triggering ML4015E Using Optical Clock Recovery Module

An optical clock recovery can be used. The recovered clock triggers the ML4015E Optical Scope to perform NRZ or PAM4 optical measurements such as TDECQ, OMA, and ER.

Test Setup Using ML4015E

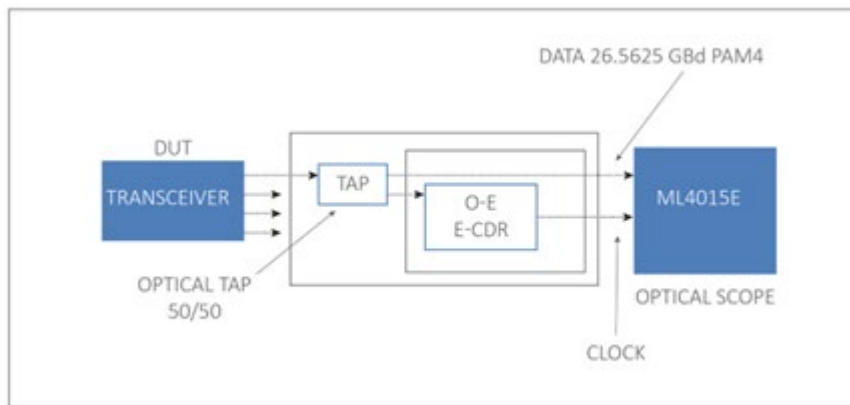

Figure 9: Functional Block Diagram of the ML4015E

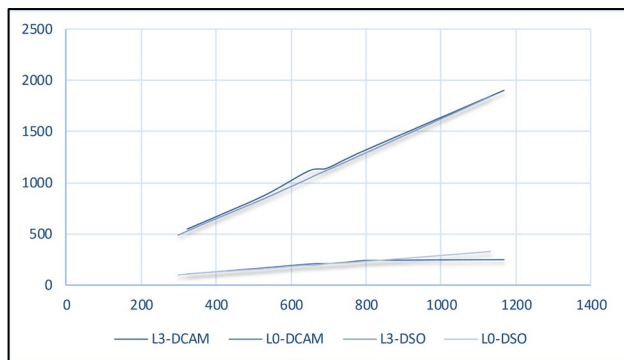

Figure 10: L1 and L3 Comparison

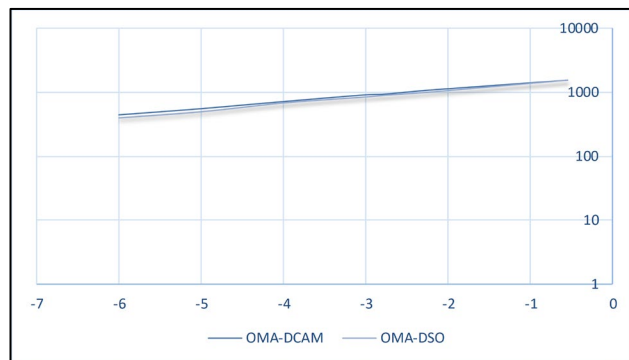

Figure 11: OMA-DCAM and OMA-DSO Comparison

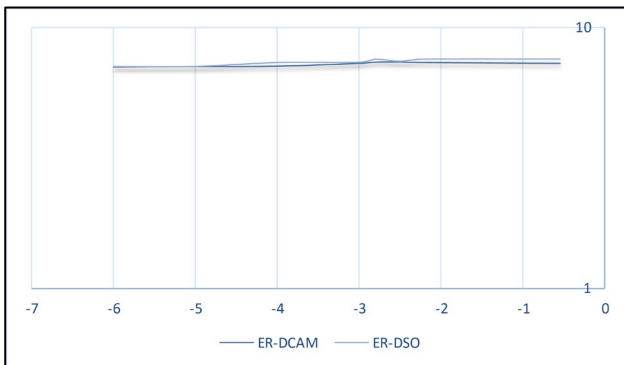

Figure 12: ER-DCAM and ER-DSO Comparison

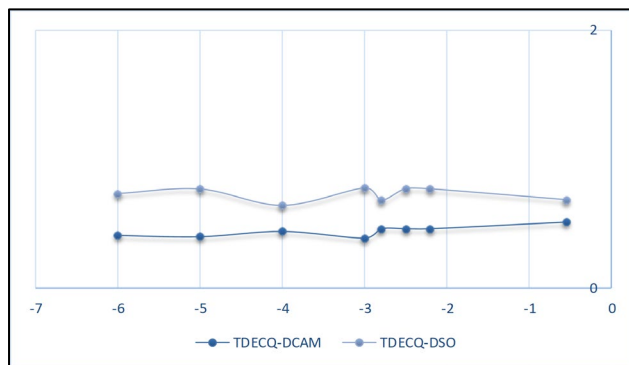

Figure 13: TDECQ-DCAM and TDECQ-DSO Comparison

Mechanical Dimensions

The ML4015E is a benchtop instrument that also fits in a 19-inch 2U rack. It has a ruggedized Enigma enclosure with improved mechanical rigidity. Two ML4015Es arranged side by side comprise one 2U slot in the rack. MultiLane also supplies the needed bracket.



Figure 14: ML4015E Mechanical Dimensions

Ordering Information

ML Part Number	Description
ML4015E-35	Electrical Diff 33 GHz BW
ML4015E-OPT-25	Single Channel Optical Broadband 25 GHz Receiver
ML4015E-2x-35	Dual Diff Electrical 33 GHz BW
ML4015E-2x-35-OPT-SM42	One Diff Electrical 33 GHz and 1 Optical Single Mode 42 GHz Receiver
ML4015E-2x-35-OPT-33	One Diff Electrical 33 GHz and 1 Optical Broadband 33 GHz Receiver

Recommended Accessories

Instruments	Recommended Cables	Comments
ML4015E-35	1x MLCBPS-2.92-30/60	2.92 mm connector, Clock Input Cable, 30 or 60 cm
	2x MLCBPS-2.4-30/60	2.4 mm connector, 2 Data in Cables, 30 or 60 cm
ML4015E-OPT-25	1x MLCBPS-2.92-30/60	2.92 mm connector, Clock Input Cable, 30 or 60 cm
ML4015E-2x-35	1x MLCBPS-2.92-30/60	2.92 mm connector, Clock Input Cable, 30 or 60 cm
	4x MLCBPS-2.4-30/60	2.4 mm connector, 4 Data in Cables, 30 or 60 cm
ML4015E-2x-35-OPT-SM42	1x MLCBPS-2.92-30/60	2.92 mm connector, Clock Input Cable, 30 or 60 cm
	2x MLCBPS-2.4-30/60	2.4 mm connector, 2 Data in Cables, 30 or 60 cm
ML4015E-2x-35-OPT-33	1x MLCBPS-2.92-30/60	2.92 mm connector, Clock Input Cable, 30 or 60 cm
	2x MLCBPS-2.4-30/60	2.4 mm connector, 2 Data in Cables, 30 or 60 cm

Please contact us at sales@multilaneinc.com

This equipment contains ESD sensitive components and may become damaged when contacted with an electrostatic charge. To prevent equipment damage, please use proper grounding techniques.

